



Starling Madison Lofquist, Inc.  
*Consulting Structural and Forensic Engineers*  
5224 South 39<sup>th</sup> Street, Phoenix, Arizona 85040  
tel: (602) 438-2500 fax: (602) 438-2505 www.smleng.com

Roof Tech, Inc.  
333 H Street, Suite 5000  
Chula Vista, CA 91910

December 4, 2015

page 1 of 13

Attn: Mr. Takashi Chiyoda, General Manager

**Subject: Roof Tech RT-[E] Mount Air – Structural Analysis**

SML Job No.: 471-13

Dear Mr. Chiyoda:

We have analyzed the Roof Tech RT-[E] Mount Air rail-less photovoltaic (PV) panel roof mount system and determined that, for the configurations and criteria described below, it is in compliance with the applicable sections of the following Reference Documents:

Codes: ASCE/SEI 7-10 Min. Design Loads for Buildings & Other Structures  
International Building Code 2012 & 2015 Editions  
International Residential Building Code 2012 & 2015 Editions  
Other: Aluminum Design Manual, 2010 Edition

The Roof Tech RT-[E] Mount Air rail-less photovoltaic (PV) panel roof mount system is comprised of a 6000 series aluminum [E] Mount Air base, panel spacer, middle clamp, end clamp, and optional shim(s), and SS304 bonding plate(s). A stainless steel SS304 8.0 mm bolt, nut, and star conical washer fasten the mounting system together, and the system is attached to the roof wood substrate with SS304 5.0 mm x 60 mm wood screws.

Three wood substrates were tested with the fasteners also passing through two layers of composite asphalt roof shingles. The first tested wood substrate consisted of 7/16" thick sheathing over a 2x4 SPF #2 rafter (2x truss top chord OK by inspection), the second tested wood substrate consisted of 7/16" thick OSB only, and the third tested wood substrate consisted of 15/32" thick plywood only. See Exhibit 'A' – attached. Two wood screws are required at the rafter installations and four wood screws are required at the OSB and plywood only installations.

The testing data provided by Western Technologies report (job) no.: 2163XD260, event no's: G260-4 revised May 30, 2014, G240-5 dated June 13, 2014, and G240-6 dated May 30, 2014, shows that the critical failure occurs in one of three ways; pullout of the wood screws from the OSB/Plywood only wood substrate, the shear failure of the OSB/Plywood only wood substrate, or the shear failure of the aluminum [E] Mount Air base at the base flange. Maximum allowable values for these failure conditions were derived using a safety factor of 2.0 on the ultimate loads provided by the testing.

**RT-[E] Mount Air PV Panel in Landscape Orientation:**

The maximum allowable uplift and shear force for 7/16" thick sheathing over a 2x4 SPF #2 rafter is 818 lb and 579 lb respectively. The maximum allowable uplift, down force and shear force for 7/16" thick OSB only is 208 lb, 258 lb, and 209 lb respectively. The maximum allowable uplift, down force and shear force for 15/32" thick plywood only is 306 lb, 556 lb, and 267 lb respectively.

**RT-[E] Mount Air PV Panel in Portrait Orientation:**

The maximum allowable uplift and shear force for 7/16" thick sheathing over a 2x4 SPF #2 rafter is 710 lb and 212 lb respectively. The maximum allowable uplift, down force and shear force for 7/16" thick OSB only is 261 lb, 258 lb, and 157 lb respectively. The maximum allowable uplift, down force and shear force for 15/32" thick plywood only is 414 lb, 556 lb, and 196 lb respectively.

The attached tables below show the maximum allowable combined loading criteria of wind speed, roof slope, and snow loads which produce reaction loads below the allowable loads listed above. The effect of seismic loads (for all design categories A-F) have been determined to be less than the effect due to wind loads in all load conditions and combinations. The assumed topography is flat with a  $K_{zt} = 1.0$ . Therefore, the maximum allowable spans for common load cases due to dead, wind and snow loads are the controlling load cases.

Roof Angle (Degrees)	Roof Slope (in/in)
0.0	0:12
4.8	1:12
9.5	2:12
14.0	3:12
18.4	4:12
22.6	5:12
26.6	6:12
33.7	8:12
39.8	10:12
45.0	12:12

Table 1. OSB Only Landscape (Maximum Panel Area = 18.88 sq. ft.)									
Maximum Design Criteria	Exposure B			Exposure C			Exposure D		
	Wind Speed (mph)	Roof Slope	Ground Snow (psf)	Wind Speed (mph)	Roof Slope	Ground Snow (psf)	Wind Speed (mph)	Roof Slope	Ground Snow (psf)
Zone 1 4 Mounts	170	2:12-6:12	15	140	2:12-6:12	15	130	2:12-6:12	15
	160	0:12-8:12	10	130	0:12-12:12	15	120	0:12-12:12	15
	160	0:12-6:12	15	120	5:12-6:12	20	120	0:12-12:12	15
	150	0:12-12:12	15	115	5:12-12:12	20	115	5:12-6:12	20
	130	5:12-12:12	20	110	6:12-12:12	25	NA	NA	NA
	130	6:12-12:12	25	NA	NA	NA	NA	NA	NA
	115	8:12-12:12	30	NA	NA	NA	NA	NA	NA
Zone 1 6 Mounts	180	0:12-12:12	35	170	2:12-6:12	30	160	2:12-6:12	30
	170	5:12-6:12	40	160	0:12-12:12	30	150	0:12-12:12	30
	160	5:12-12:12	40	160	4:12-6:12	35	150	5:12-6:12	35
	150	6:12-12:12	45	150	0:12-12:12	35	140	0:12-12:12	35
	140	8:12-12:12	50	140	5:12-12:12	40	130	5:12-12:12	40
	NA	NA	NA	130	6:12-12:12	45	120	6:12-12:12	45
	NA	NA	NA	115	8:12-12:12	50	NA	NA	NA
Zone 2 4 Mounts	140	8:12-12:12	15	120	8:12-12:12	15	110	8:12-12:12	15
	130	8:12-12:12	25	115	8:12-12:12	20	NA	NA	NA
	120	0:12-12:12	15	110	8:12-12:12	25	NA	NA	NA
	120	5:12-12:12	20	NA	NA	NA	NA	NA	NA
	120	6:12-12:12	25	NA	NA	NA	NA	NA	NA
	115	8:12-12:12	30	NA	NA	NA	NA	NA	NA
Zone 2 6 Mounts	170	8:12-12:12	35	150	8:12-10:12	35	130	8:12-12:12	40
	160	8:12-12:12	40	140	8:12-12:12	40	120	8:12-12:12	45
	150	2:12-12:12	35	130	8:12-12:12	45	115	0:12-12:12	35
	150	5:12-12:12	40	120	0:12-12:12	35	115	5:12-12:12	40
	150	6:12-12:12	45	120	5:12-12:12	40	115	6:12-12:12	45
	140	0:12-12:12	35	120	6:12-12:12	45	NA	NA	NA
	140	8:12-12:12	50	115	8:12-12:12	50	NA	NA	NA
Zone 3 4 Mounts	140	8:12-12:12	15	120	8:12-12:12	15	110	8:12-12:12	15
	130	8:12-12:12	25	110	8:12-12:12	25	NA	NA	NA
	115	8:12-12:12	30	NA	NA	NA	NA	NA	NA
Zone 3 6 Mounts	170	8:12-12:12	35	150	8:12-10:12	35	130	8:12-12:12	40
	160	8:12-12:12	40	140	8:12-12:12	40	120	8:12-12:12	45
	150	8:12-12:12	45	130	8:12-12:12	45	NA	NA	NA
	140	8:12-12:12	50	115	8:12-12:12	50	NA	NA	NA
	120	2:12-12:12	35	NA	NA	NA	NA	NA	NA
	120	5:12-12:12	40	NA	NA	NA	NA	NA	NA
	120	6:12-12:12	45	NA	NA	NA	NA	NA	NA
	115	0:12-12:12	35	NA	NA	NA	NA	NA	NA

Table 2. OSB Only Portrait (Maximum Panel Area = 18.88 sq. ft.)									
Maximum Design Criteria	Exposure B			Exposure C			Exposure D		
	Wind Speed (mph)	Roof Slope	Ground Snow (psf)	Wind Speed (mph)	Roof Slope	Ground Snow (psf)	Wind Speed (mph)	Roof Slope	Ground Snow (psf)
Zone 1 4 Mounts	180	2:12-6:12	10	150	0:12-6:12	10	140	2:12-6:12	10
	170	0:12-6:12	10	140	0:12-12:12	10	130	0:12-10:12	10
	160	0:12-12:12	10	140	0:12-6:12	15	120	0:12-12:12	10
	160	0:12-6:12	15	120	0:12-12:12	15	120	0:12-6:12	15
	150	0:12-12:12	15	NA	NA	NA	115	0:12-12:12	15
	115	8:12-12:12	25	NA	NA	NA	NA	NA	NA
Zone 1 6 Mounts	180	0:12-12:12	25	180	0:12-6:12	25	170	2:12-6:12	25
	180	0:12-6:12	30	170	0:12-12:12	20	160	0:12-12:12	15
	170	0:12-12:12	30	170	5:12-6:12	30	160	5:12-6:12	30
	140	8:12-12:12	40	160	0:12-12:12	25	150	0:12-12:12	20
	NA	NA	NA	160	0:12-6:12	30	150	0:12-6:12	30
	NA	NA	NA	150	0:12-12:12	30	140	0:12-12:12	25
	NA	NA	NA	150	5:12-6:12	35	130	0:12-12:12	30
	NA	NA	NA	140	4:12-6:12	35	130	4:12-6:12	35
	NA	NA	NA	130	4:12-12:12	35	120	4:12-12:12	35
NA	NA	NA	120	8:12-12:12	40	115	8:12-12:12	40	
Zone 2 4 Mounts	150	8:12-12:12	10	130	8:12-12:12	10	120	8:12-12:12	10
	130	0:12-12:12	15	120	8:12-12:12	15	NA	NA	NA
	115	8:12-12:12	25	110	0:12-12:12	15	NA	NA	NA
Zone 2 6 Mounts	180	8:12-12:12	25	160	8:12-12:12	25	140	8:12-12:12	25
	170	8:12-12:12	30	150	8:12-12:12	30	130	8:12-12:12	30
	160	0:12-12:12	30	130	0:12-12:12	30	120	0:12-12:12	30
	160	4:12-12:12	35	130	4:12-12:12	35	120	4:12-12:12	35
	130	8:12-12:12	45	120	8:12-12:12	40	115	8:12-12:12	40
	NA	NA	NA	110	8:12-12:12	45	NA	NA	NA
Zone 3 4 Mounts	150	8:12-12:12	10	130	8:12-12:12	10	120	8:12-12:12	10
	130	8:12-12:12	15	120	8:12-12:12	15	NA	NA	NA
	115	8:12-12:12	25	NA	NA	NA	NA	NA	NA
Zone 3 6 Mounts	180	8:12-12:12	25	160	8:12-12:12	25	140	8:12-12:12	25
	170	8:12-12:12	30	150	8:12-12:12	30	130	8:12-12:12	30
	160	8:12-12:12	35	130	8:12-12:12	35	120	8:12-12:12	35
	140	8:12-12:12	40	120	8:12-12:12	40	115	8:12-12:12	40
	130	2:12-12:12	30	110	2:12-12:12	30	NA	NA	NA
	130	4:12-12:12	35	110	4:12-12:12	35	NA	NA	NA
	130	8:12-12:12	45	110	8:12-12:12	45	NA	NA	NA
	120	0:12-12:12	30	NA	NA	NA	NA	NA	NA

Table 3. Plywood Only Landscape (Maximum Panel Area = 18.88 sq. ft.)									
Maximum Design Criteria	Exposure B			Exposure C			Exposure D		
	Wind Speed (mph)	Roof Slope	Ground Snow (psf)	Wind Speed (mph)	Roof Slope	Ground Snow (psf)	Wind Speed (mph)	Roof Slope	Ground Snow (psf)
Zone 1 4 Mounts	180	0:12-12:12	45	170	2:12-6:12	45	160	2:12-4:12	45
	180	6:12-12:12	50	160	0:12-12:12	45	150	0:12-8:12	45
	170	8:12-12:12	55	150	6:12-12:12	50	140	0:12-12:12	45
	150	8:12-12:12	60	140	8:12-12:12	55	140	6:12-12:12	50
	NA	NA	NA	120	8:12-12:12	60	130	8:12-12:12	55
	NA	NA	NA	NA	NA	NA	115	8:12-12:12	60
Zone 1 6 Mounts	180	0:12-12:12	70	180	0:12-12:12	70	180	0:12-12:12	70
	180	5:12-12:12	75	180	5:12-12:12	75	180	5:12-12:12	75
	180	6:12-12:12	80	180	6:12-12:12	80	170	6:12-12:12	80
	180	8:12-12:12	90	180	8:12-12:12	85	160	8:12-12:12	85
	NA	NA	NA	160	8:12-12:12	90	150	8:12-12:12	90
Zone 2 4 Mounts	170	8:12-12:12	55	140	8:12-12:12	55	130	8:12-12:12	55
	150	2:12-4:12	45	120	0:12-12:12	45	115	2:12-12:12	45
	150	8:12-12:12	60	120	6:12-12:12	50	115	6:12-12:12	50
	140	0:12-12:12	45	120	8:12-12:12	60	115	8:12-12:12	60
	140	6:12-12:12	50	NA	NA	NA	110	0:12-12:12	45
Zone 2 6 Mounts	180	2:12-12:12	70	180	8:12-12:12	85	160	8:12-12:12	85
	180	5:12-12:12	75	160	8:12-12:12	90	150	8:12-12:12	90
	180	6:12-12:12	80	150	0:12-12:12	70	140	2:12-12:12	70
	180	8:12-12:12	90	150	5:12-12:12	75	140	5:12-12:12	75
	170	0:12-12:12	70	150	6:12-12:12	80	140	6:12-12:12	80
	NA	NA	NA	NA	NA	NA	130	0:12-12:12	70
Zone 3 4 Mounts	170	8:12-12:12	55	140	8:12-12:12	55	130	8:12-12:12	55
	150	8:12-12:12	60	120	8:12-12:12	60	115	8:12-12:12	60
	120	2:12-12:12	45	NA	NA	NA	NA	NA	NA
	120	6:12-12:12	50	NA	NA	NA	NA	NA	NA
	115	0:12-12:12	45	NA	NA	NA	NA	NA	NA
Zone 3 6 Mounts	180	8:12-12:12	90	180	8:12-12:12	85	160	8:12-12:12	85
	140	0:12-12:12	70	160	8:12-12:12	90	150	8:12-12:12	90
	140	5:12-12:12	75	120	0:12-12:12	70	110	0:12-12:12	70
	140	6:12-12:12	80	120	5:12-12:12	75	110	5:12-12:12	75
	NA	NA	NA	120	6:12-12:12	80	110	6:12-12:12	80

Table 4. Plywood Only Portrait (Maximum Panel Area = 18.88 sq. ft.)									
Maximum Design Criteria	Exposure B			Exposure C			Exposure D		
	Wind Speed (mph)	Roof Slope	Ground Snow (psf)	Wind Speed (mph)	Roof Slope	Ground Snow (psf)	Wind Speed (mph)	Roof Slope	Ground Snow (psf)
Zone 1 4 Mounts	180	0:12-12:12	40	180	0:12-12:12	30	170	0:12-6:12	35
	160	8:12-12:12	45	180	0:12-6:12	35	160	0:12-12:12	30
	NA	NA	NA	170	0:12-12:12	35	160	0:12-6:12	40
	NA	NA	NA	170	0:12-6:12	40	150	0:12-12:12	35
	NA	NA	NA	150	0:12-12:12	40	140	0:12-12:12	40
	NA	NA	NA	140	8:12-12:12	45	120	8:12-12:12	45
Zone 1 6 Mounts	180	0:12-12:12	60	180	0:12-12:12	60	180	0:12-12:12	60
	180	6:12-12:12	65	180	6:12-12:12	65	170	6:12-12:12	65
	180	8:12-12:12	70	170	8:12-12:12	70	160	8:12-12:12	70
	NA	NA	NA	160	8:12-12:12	75	140	8:12-12:12	75
Zone 2 4 Mounts	180	8:12-12:12	40	160	8:12-12:12	35	150	8:12-12:12	35
	160	0:12-12:12	40	150	8:12-12:12	40	140	8:12-12:12	40
	160	8:12-12:12	45	140	2:12-12:12	40	130	2:12-4:12	40
	NA	NA	NA	140	8:12-12:12	45	120	0:12-12:12	40
	NA	NA	NA	130	0:12-12:12	40	120	8:12-12:12	45
Zone 2 6 Mounts	180	0:12-12:12	60	180	8:12-12:12	65	180	8:12-12:12	60
	180	6:12-12:12	65	170	2:12-12:12	60	170	8:12-12:12	65
	180	8:12-12:12	75	170	6:12-12:12	65	160	8:12-12:12	70
	NA	NA	NA	170	8:12-12:12	70	150	0:12-12:12	60
	NA	NA	NA	160	0:12-12:12	60	150	6:12-12:12	65
	NA	NA	NA	160	8:12-12:12	75	140	8:12-12:12	75
Zone 3 4 Mounts	180	8:12-12:12	40	160	8:12-12:12	35	150	8:12-12:12	35
	160	8:12-12:12	45	150	8:12-12:12	40	140	8:12-12:12	40
	130	0:12-12:12	40	140	8:12-12:12	45	120	8:12-12:12	45
	NA	NA	NA	110	0:12-12:12	40	NA	NA	NA
Zone 3 6 Mounts	180	8:12-12:12	75	180	8:12-12:12	65	180	8:12-12:12	60
	160	0:12-12:12	60	170	8:12-12:12	70	170	8:12-12:12	65
	160	6:12-12:12	65	160	8:12-12:12	75	160	8:12-12:12	70
	NA	NA	NA	140	2:12-4:12	60	140	8:12-12:12	75
	NA	NA	NA	130	0:12-12:12	60	120	0:12-12:12	60
	NA	NA	NA	130	6:12-12:12	65	120	6:12-12:12	65

Table 5. Rafter Landscape (Maximum Panel Area = 18.88 sq. ft.)									
	Exposure B			Exposure C			Exposure D		
Maximum Design Criteria	Wind Speed (mph)	Roof Slope	Ground Snow (psf)	Wind Speed (mph)	Roof Slope	Ground Snow (psf)	Wind Speed (mph)	Roof Slope	Ground Snow (psf)
Zone 1 4 Mounts	180	0:12-12:12	113	180	0:12-12:12	113	180	0:12-12:12	113
	NA	NA	NA	NA	NA	NA	NA	NA	NA
Zone 2 4 Mounts	180	0:12-12:12	113	180	0:12-12:12	113	180	0:12-12:12	113
	NA	NA	NA	NA	NA	NA	NA	NA	NA
Zone 3 4 Mounts	180	0:12-12:12	113	180	8:12-12:12	113	180	8:12-12:12	113
	NA	NA	NA	160	0:12-12:12	113	150	2:12-12:12	113
	NA	NA	NA	NA	NA	NA	140	0:12-12:12	113
Zone 3 6 Mounts	180	0:12-12:12	113	180	0:12-12:12	113	180	0:12-12:12	113
	NA	NA	NA	NA	NA	NA	NA	NA	NA

Table 6. Rafter Portrait (Maximum Panel Area = 18.88 sq. ft.)									
	Exposure B			Exposure C			Exposure D		
Maximum Design Criteria	Wind Speed (mph)	Roof Slope	Ground Snow (psf)	Wind Speed (mph)	Roof Slope	Ground Snow (psf)	Wind Speed (mph)	Roof Slope	Ground Snow (psf)
Zone 1 4 Mounts	180	0:12-12:12	80	180	0:12-12:12	80	180	0:12-12:12	80
	180	0:12-5:12	85	180	0:12-5:12	85	180	0:12-5:12	85
	180	8:12-12:12	85	180	8:12-12:12	85	180	8:12-12:12	85
	180	0:12-4:12	90	180	0:12-4:12	90	180	0:12-4:12	90
	180	0:12-3:12	113	180	0:12-3:12	113	180	0:12-3:12	113
Zone 1 6 Mounts	180	0:12-12:12	113	180	0:12-12:12	113	180	0:12-12:12	113
	NA	NA	NA	NA	NA	NA	NA	NA	NA
Zone 2 4 Mounts	180	0:12-12:12	80	180	0:12-12:12	80	180	8:12-12:12	85
	180	0:12-5:12	85	180	0:12-5:12	85	170	0:12-12:12	80
	180	8:12-12:12	85	180	8:12-12:12	85	170	0:12-5:12	85
	180	0:12-4:12	90	180	0:12-4:12	90	170	0:12-4:12	90
	180	0:12-3:12	113	180	0:12-3:12	113	170	0:12-3:12	113
Zone 2 6 Mounts	180	0:12-12:12	113	180	0:12-12:12	113	180	0:12-12:12	113
	NA	NA	NA	NA	NA	NA	NA	NA	NA
Zone 3 4 Mounts	180	2:12-12:12	80	180	8:12-12:12	85	180	8:12-12:12	85
	180	2:12-5:12	85	150	2:12-12:12	80	140	2:12-12:12	80
	180	8:12-12:12	85	150	2:12-5:12	85	140	2:12-5:12	85
	180	2:12-4:12	90	150	2:12-4:12	90	140	2:12-4:12	90
	170	0:12-12:12	80	140	0:12-12:12	80	130	0:12-12:12	80
	170	0:12-5:12	85	140	0:12-5:12	85	130	0:12-5:12	85
	170	0:12-4:12	90	140	0:12-4:12	90	130	0:12-4:12	90
Zone 3 6 Mounts	170	0:12-3:12	113	140	0:12-3:12	113	130	0:12-3:12	113
	180	0:12-12:12	113	180	0:12-12:12	113	180	8:12-12:12	113
	NA	NA	NA	NA	NA	NA	170	2:12-12:12	113
	NA	NA	NA	NA	NA	NA	160	0:12-12:12	113

Table 7. OSB Only Landscape (Maximum Panel Area = 21.0 sq. ft.)									
Maximum Design Criteria	Exposure B			Exposure C			Exposure D		
	Wind Speed (mph)	Roof Slope	Ground Snow (psf)	Wind Speed (mph)	Roof Slope	Ground Snow (psf)	Wind Speed (mph)	Roof Slope	Ground Snow (psf)
Zone 1 4 Mounts	160	2:12-6:12	10	130	0:12-6:12	15	120	0:12-6:12	10
	150	0:12-6:12	15	120	0:12-12:12	10	115	0:12-12:12	10
	150	0:12-12:12	10	115	0:12-12:12	15	NA	NA	NA
	130	0:12-12:12	15	NA	NA	NA	NA	NA	NA
	115	8:12-12:12	20	NA	NA	NA	NA	NA	NA
Zone 1 6 Mounts	180	0:12-12:12	25	160	2:12-6:12	25	150	2:12-6:12	25
	180	0:12-6:12	30	150	0:12-12:12	25	140	0:12-12:12	25
	170	0:12-12:12	30	150	0:12-6:12	30	140	0:12-6:12	30
	150	5:12-12:12	35	140	0:12-12:12	30	130	0:12-12:12	30
	140	6:12-12:12	40	130	5:12-12:12	35	120	5:12-12:12	35
	130	8:12-12:12	45	120	6:12-12:12	40	110	6:12-12:12	40
	NA	NA	NA	110	8:12-12:12	45	NA	NA	NA
Zone 2 4 Mounts	130	8:12-12:12	15	115	8:12-12:12	15	NA	NA	NA
	115	8:12-12:12	20	NA	NA	NA	NA	NA	NA
	115	0:12-12:12	15	NA	NA	NA	NA	NA	NA
	110	8:12-12:12	25	NA	NA	NA	NA	NA	NA
Zone 2 6 Mounts	160	8:12-12:12	30	140	8:12-10:12	30	130	8:12-12:12	30
	150	8:12-12:12	35	130	8:12-12:12	35	120	8:12-12:12	35
	140	0:12-12:12	30	120	2:12-12:12	30	110	2:12-12:12	30
	140	5:12-12:12	35	120	5:12-12:12	35	110	5:12-12:12	35
	140	6:12-12:12	40	120	6:12-12:12	40	110	6:12-12:12	40
	130	8:12-12:12	45	115	0:12-12:12	30	NA	NA	NA
	NA	NA	NA	110	8:12-12:12	45	NA	NA	NA
Zone 3 4 Mounts	130	8:12-12:12	15	115	8:12-12:12	15	NA	NA	NA
	115	8:12-12:12	20	NA	NA	NA	NA	NA	NA
	110	8:12-12:12	25	NA	NA	NA	NA	NA	NA
Zone 3 6 Mounts	160	8:12-12:12	30	140	8:12-10:12	30	130	8:12-12:12	30
	150	8:12-12:12	35	130	8:12-12:12	35	120	8:12-12:12	35
	140	8:12-12:12	40	120	8:12-12:12	40	110	8:12-12:12	40
	130	8:12-12:12	45	110	8:12-12:12	45	NA	NA	NA
	115	2:12-12:12	30	NA	NA	NA	NA	NA	NA
	115	5:12-12:12	35	NA	NA	NA	NA	NA	NA
	115	6:12-12:12	40	NA	NA	NA	NA	NA	NA
	110	0:12-12:12	30	NA	NA	NA	NA	NA	NA



Table 8. OSB Only Portrait (Maximum Panel Area = 21.0 sq. ft.)									
Maximum Design Criteria	Exposure B			Exposure C			Exposure D		
	Wind Speed (mph)	Roof Slope	Ground Snow (psf)	Wind Speed (mph)	Roof Slope	Ground Snow (psf)	Wind Speed (mph)	Roof Slope	Ground Snow (psf)
Zone 1 4 Mounts	170	2:12-6:12	10	140	0:12-6:12	10	130	0:12-6:12	10
	160	0:12-6:12	10	130	0:12-12:12	5	120	0:12-12:12	5
	150	0:12-12:12	5	120	0:12-12:12	10	115	0:12-6:12	10
	140	0:12-12:12	10	NA	NA	NA	110	0:12-12:12	10
	120	6:12-12:12	15	NA	NA	NA	NA	NA	NA
Zone 1 6 Mounts	180	0:12-12:12	15	180	2:12-6:12	15	160	0:12-6:12	20
	180	0:12-6:12	25	170	0:12-6:12	20	150	0:12-6:12	25
	170	0:12-12:12	25	160	0:12-12:12	15	150	0:12-12:12	10
	160	0:12-6:12	30	160	0:12-6:12	25	140	0:12-12:12	15
	150	0:12-12:12	30	140	0:12-12:12	25	130	0:12-12:12	25
	140	8:12-12:12	35	140	0:12-6:12	30	120	0:12-12:12	30
	120	8:12-12:12	40	130	0:12-12:12	30	NA	NA	NA
NA	NA	NA	115	8:12-12:12	35	NA	NA	NA	
Zone 2 4 Mounts	140	8:12-12:12	10	120	8:12-12:12	10	115	8:12-12:12	10
	120	0:12-12:12	10	NA	NA	NA	NA	NA	NA
	120	6:12-12:12	15	NA	NA	NA	NA	NA	NA
Zone 2 6 Mounts	180	8:12-12:12	15	150	8:12-12:12	15	140	8:12-12:12	15
	170	8:12-12:12	25	140	8:12-12:12	25	120	2:12-12:12	30
	150	0:12-12:12	30	130	2:12-12:12	30	115	0:12-12:12	30
	140	8:12-12:12	35	120	0:12-12:12	30	NA	NA	NA
	120	8:12-12:12	40	115	8:12-12:12	35	NA	NA	NA
Zone 3 4 Mounts	140	8:12-12:12	10	120	8:12-12:12	10	110	8:12-12:12	10
	120	8:12-12:12	15	NA	NA	NA	NA	NA	NA
Zone 3 6 Mounts	180	8:12-12:12	15	150	8:12-12:12	15	140	8:12-12:12	15
	170	8:12-12:12	25	140	8:12-12:12	25	130	8:12-12:12	25
	150	8:12-12:12	30	130	8:12-12:12	30	120	8:12-12:12	30
	140	8:12-12:12	35	115	8:12-12:12	35	NA	NA	NA
	120	0:12-12:12	30	NA	NA	NA	NA	NA	NA
	120	8:12-12:12	40	NA	NA	NA	NA	NA	NA

Table 9. Plywood Only Landscape (Maximum Panel Area = 21.0 sq. ft.)									
Maximum Design Criteria	Exposure B			Exposure C			Exposure D		
	Wind Speed (mph)	Roof Slope	Ground Snow (psf)	Wind Speed (mph)	Roof Slope	Ground Snow (psf)	Wind Speed (mph)	Roof Slope	Ground Snow (psf)
Zone 1 4 Mounts	180	0:12-12:12	40	160	2:12-6:12	40	150	2:12-6:12	40
	170	6:12-12:12	45	150	0:12-12:12	40	140	0:12-12:12	40
	150	8:12-12:12	50	140	6:12-12:12	45	130	6:12-12:12	45
	NA	NA	NA	130	8:12-12:12	50	120	8:12-12:12	50
Zone 1 6 Mounts	180	0:12-12:12	65	180	0:12-12:12	65	180	2:12-6:12	65
	180	6:12-12:12	70	180	6:12-12:12	70	170	0:12-12:12	65
	180	8:12-12:12	80	170	8:12-12:12	75	160	6:12-12:12	70
	NA	NA	NA	160	8:12-12:12	80	150	8:12-12:12	75
	NA	NA	NA	NA	NA	NA	140	8:12-12:12	80
Zone 2 4 Mounts	160	8:12-12:12	45	140	8:12-12:12	45	120	8:12-12:12	50
	150	8:12-12:12	50	130	8:12-12:12	50	110	2:12-5:12	40
	140	2:12-12:12	40	120	2:12-5:12	40	110	6:12-12:12	45
	140	6:12-12:12	45	115	6:12-12:12	45	NA	NA	NA
	130	0:12-12:12	40	115	0:12-12:12	40	NA	NA	NA
	120	6:12-12:12	45	NA	NA	NA	NA	NA	NA
Zone 2 6 Mounts	180	8:12-12:12	80	170	8:12-12:12	75	150	8:12-12:12	75
	170	2:12-12:12	65	160	8:12-12:12	80	140	8:12-12:12	80
	170	6:12-12:12	70	140	0:12-12:12	65	130	6:12-12:12	70
	160	0:12-12:12	65	140	6:12-12:12	70	130	0:12-12:12	65
Zone 3 4 Mounts	150	8:12-12:12	50	130	8:12-12:12	50	120	8:12-12:12	50
	115	2:12-5:12	40	NA	NA	NA	NA	NA	NA
	110	6:12-12:12	45	NA	NA	NA	NA	NA	NA
	110	0:12-12:12	40	NA	NA	NA	NA	NA	NA
Zone 3 6 Mounts	180	8:12-12:12	80	170	8:12-12:12	75	150	8:12-12:12	75
	140	2:12-5:12	65	160	8:12-12:12	80	140	8:12-12:12	80
	130	0:12-12:12	65	115	0:12-12:12	65	NA	NA	NA
	130	6:12-12:12	70	115	6:12-12:12	70	NA	NA	NA

Table 10. Plywood Only Portrait (Maximum Panel Area = 21.0 sq. ft.)									
Maximum Design Criteria	Exposure B			Exposure C			Exposure D		
	Wind Speed (mph)	Roof Slope	Ground Snow (psf)	Wind Speed (mph)	Roof Slope	Ground Snow (psf)	Wind Speed (mph)	Roof Slope	Ground Snow (psf)
Zone 1 4 Mounts	180	0:12-12:12	30	180	2:12-6:12	30	170	2:12-4:12	30
	180	0:12-6:12	35	170	0:12-12:12	25	160	0:12-6:12	30
	170	0:12-12:12	35	170	0:12-6:12	30	150	0:12-12:12	30
	150	8:12-12:12	40	160	0:12-12:12	30	150	0:12-6:12	35
	NA	NA	NA	160	0:12-6:12	35	130	0:12-12:12	35
	NA	NA	NA	140	0:12-12:12	35	120	8:12-12:12	40
	NA	NA	NA	130	8:12-12:12	40	NA	NA	NA
Zone 1 6 Mounts	180	0:12-12:12	55	180	0:12-12:12	55	180	0:12-12:12	50
	180	8:12-12:12	65	170	8:12-12:12	60	180	0:12-6:12	55
	NA	NA	NA	150	8:12-12:12	65	170	0:12-12:12	55
	NA	NA	NA	NA	NA	NA	150	8:12-12:12	60
	NA	NA	NA	NA	NA	NA	140	8:12-12:12	65
Zone 2 4 Mounts	180	8:12-12:12	30	150	8:12-12:12	30	140	8:12-12:12	30
	170	8:12-12:12	35	140	8:12-12:12	35	130	8:12-12:12	35
	150	0:12-12:12	35	140	2:12-12:12	40	120	0:12-12:12	35
	150	8:12-12:12	40	130	0:12-12:12	35	120	8:12-12:12	40
	NA	NA	NA	130	8:12-12:12	40	NA	NA	NA
Zone 2 6 Mounts	180	0:12-12:12	55	180	8:12-12:12	55	170	8:12-12:12	55
	180	8:12-12:12	65	170	6:12-12:12	60	150	8:12-12:12	60
	NA	NA	NA	170	8:12-12:12	60	150	2:12-12:12	55
	NA	NA	NA	160	0:12-12:12	55	140	8:12-12:12	65
	NA	NA	NA	150	8:12-12:12	65	130	0:12-12:12	55
Zone 3 4 Mounts	180	8:12-12:12	30	150	8:12-12:12	30	140	8:12-12:12	30
	170	8:12-12:12	35	140	8:12-12:12	35	130	8:12-12:12	35
	150	8:12-12:12	40	130	8:12-12:12	40	120	8:12-12:12	40
	120	0:12-12:12	35	NA	NA	NA	NA	NA	NA
Zone 3 6 Mounts	180	8:12-12:12	65	180	8:12-12:12	55	170	8:12-12:12	55
	150	0:12-12:12	55	170	8:12-12:12	60	150	8:12-12:12	60
	NA	NA	NA	150	8:12-12:12	65	140	8:12-12:12	65
	NA	NA	NA	130	2:12-12:12	55	120	2:12-12:12	55
	NA	NA	NA	120	0:12-12:12	55	115	0:12-12:12	55

Table 11. Rafter Landscape (Maximum Panel Area = 21.0 sq. ft.)									
Maximum Design Criteria	Exposure B			Exposure C			Exposure D		
	Wind Speed (mph)	Roof Slope	Ground Snow (psf)	Wind Speed (mph)	Roof Slope	Ground Snow (psf)	Wind Speed (mph)	Roof Slope	Ground Snow (psf)
Zone 1 4 Mounts	180	0:12-12:12	113	180	0:12-12:12	113	180	0:12-12:12	90
	NA	NA	NA	NA	NA	NA	NA	NA	NA
Zone 2 4 Mounts	180	0:12-12:12	113	180	0:12-12:12	113	180	8:12-12:12	113
	NA	NA	NA	NA	NA	NA	170	0:12-12:12	113
Zone 2 6 Mounts	180	0:12-12:12	113	180	0:12-12:12	113	180	0:12-12:12	113
	NA	NA	NA	NA	NA	NA	NA	NA	NA
Zone 3 4 Mounts	180	0:12-12:12	113	180	8:12-12:12	113	180	8:12-12:12	113
	NA	NA	NA	150	0:12-12:12	113	140	0:12-12:12	113
Zone 3 6 Mounts	180	0:12-12:12	113	180	0:12-12:12	113	180	8:12-12:12	113
	NA	NA	NA	NA	NA	NA	170	0:12-12:12	113

Table 12. Rafter Portrait (Maximum Panel Area = 21.0 sq. ft.)									
Maximum Design Criteria	Exposure B			Exposure C			Exposure D		
	Wind Speed (mph)	Roof Slope	Ground Snow (psf)	Wind Speed (mph)	Roof Slope	Ground Snow (psf)	Wind Speed (mph)	Roof Slope	Ground Snow (psf)
Zone 1 4 Mounts	180	0:12-12:12	70	180	0:12-12:12	80	180	0:12-12:12	80
	180	0:12-5:12	75	180	0:12-5:12	85	180	0:12-5:12	85
	180	0:12-4:12	85	180	0:12-4:12	90	180	0:12-4:12	90
	180	0:12-3:12	100	180	0:12-3:12	100	180	0:12-3:12	100
Zone 1 6 Mounts	180	0:12-12:12	113	180	0:12-12:12	113	180	0:12-12:12	113
	NA	NA	NA	NA	NA	NA	NA	NA	NA
Zone 2 4 Mounts	180	0:12-12:12	70	180	8:12-12:12	75	180	8:12-12:12	75
	180	0:12-5:12	75	180	2:12-4:12	85	160	0:12-12:12	70
	180	8:12-12:12	75	170	0:12-12:12	70	160	0:12-5:12	75
	180	0:12-4:12	85	170	0:12-5:12	75	160	0:12-4:12	85
	180	0:12-3:12	100	170	0:12-3:12	100	160	0:12-3:12	100
Zone 2 6 Mounts	180	0:12-12:12	113	180	0:12-12:12	113	180	0:12-12:12	113
	NA	NA	NA	NA	NA	NA	NA	NA	NA
Zone 3 4 Mounts	180	8:12-12:12	75	180	8:12-12:12	75	180	8:12-12:12	75
	170	2:12-12:12	70	140	0:12-12:12	70	130	0:12-12:12	70
	170	2:12-5:12	75	140	0:12-5:12	75	130	0:12-5:12	75
	170	2:12-4:12	85	140	0:12-4:12	85	130	0:12-4:12	85
	160	0:12-12:12	70	140	0:12-3:12	100	130	0:12-3:12	100
	160	0:12-5:12	75	NA	NA	NA	NA	NA	NA
	160	0:12-4:12	85	NA	NA	NA	NA	NA	NA
Zone 3 6 Mounts	180	0:12-12:12	113	180	8:12-12:12	113	180	8:12-12:12	113
	NA	NA	NA	170	0:12-12:12	113	160	2:12-12:12	113
	NA	NA	NA	NA	NA	NA	150	0:12-12:12	113

Table Notes – Tabulated values are based on the following criteria:

1. Building mean roof height = 30 ft maximum.
2. Risk Category = II.
3. Solar panel maximum area as indicated in header of each table.
4. Solar panel dead load = approximately 3.0 psf.
5. ASCE 7-10.
6. OSB shall be 24/16 APA rated sheathing minimum (7/16" thick).
7. Plywood shall be 32/16 APA rated sheathing minimum (15/32" thick).
8. Sheathing shall be free of defects including, but not limited to water damage and delamination.
9. Roof rafters or trusses spaced at 24" on center maximum.
10. PV panels must be supported per the manufacturer required orientation, location and/or spacing.
11. Through a maximum of 2 layers of composite asphalt roof shingles or maximum 20 gage metal decking provided the metal is predrilled as wood screws are not designed to penetrate the metal decking. Not valid on concrete roof tile.

Our analysis assumes that the connections and associated hardware are installed in a workmanlike manner in accordance with the RT-[E] Mount Air Installation Manual and generally accepted standards of construction practice. It is the responsibility of the contractor to verify that the strength of the roof framing meets the minimum properties used in the tests and can safely support the maximum imposed loads stated within this document. Starling Madison Lofquist, Inc. and Roof Tech assume no liability beyond what is specifically shown in this letter. Additional information is available at the Roof Tech web site, <http://www.roof-tech.us/>.

Please feel free to contact me at your convenience if you have any questions.

Respectfully yours,

Tres J. Warner, P.E.  
Design Division Manager

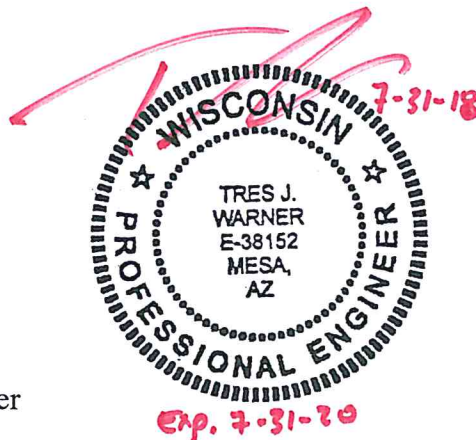

Jesse Light, P.E.  
Sr. Structural Engineer

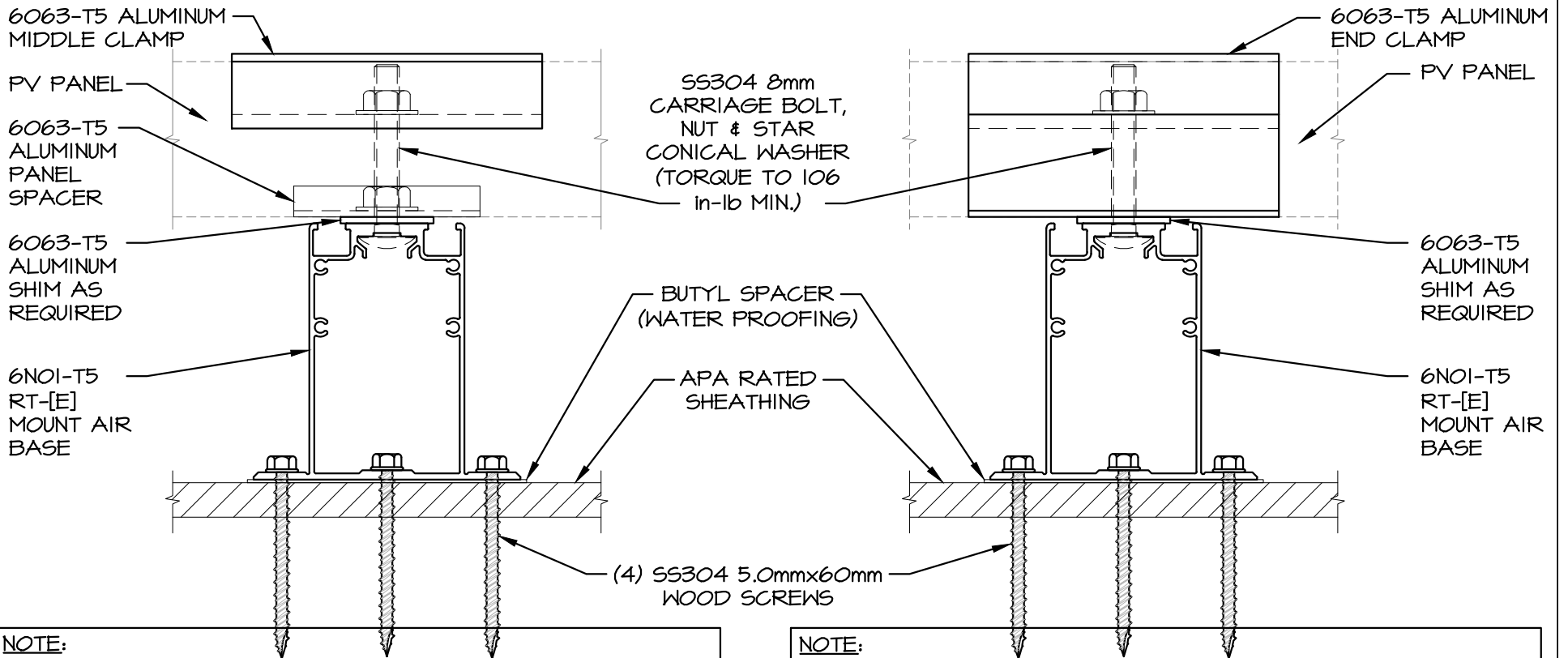

**NOTE:**  
 PROVIDE SS304 BONDING PLATE(S) (NOT SHOWN FOR CLARITY) BETWEEN PANEL SPACER & RT-[E] MOUNT AIR BASE OR SHIM IF USED. WHEN SHIM IS USED PROVIDE ADDITIONAL BONDING PLATE BETWEEN SHIM & RT-[E] MOUNT AIR BASE

**NOTE:**  
 PROVIDE SS304 BONDING PLATE(S) (NOT SHOWN FOR CLARITY) BETWEEN END CAP & RT-[E] MOUNT AIR BASE OR SHIM IF USED. WHEN SHIM IS USED PROVIDE ADDITIONAL BONDING PLATE BETWEEN SHIM & RT-[E] MOUNT AIR BASE

MIDDLE CONNECTION

END CONNECTION

1 OSB/PLYWOOD ONLY CONNECTION

SCALE: N.T.S.



Starling Madison Lofquist, Inc.  
 5224 S. 39th Street  
 Phoenix, Arizona 85040  
 (602) 438-2500  
 fax. (602) 438-2505

DRAWN BY: T.M.  
 DESIGNED BY: J.L.

DATE: 7-21-15  
 JOB NO: 471-13

ROOF TECH  
 RT-[E] MOUNT AIR  
 STRUCTURAL ANALYSIS

ROOF TECH, INC.  
 333 H STREET, SUITE 5000  
 CHULA VISTA, CA 91910

EXHIBIT A  
 1 OF 4

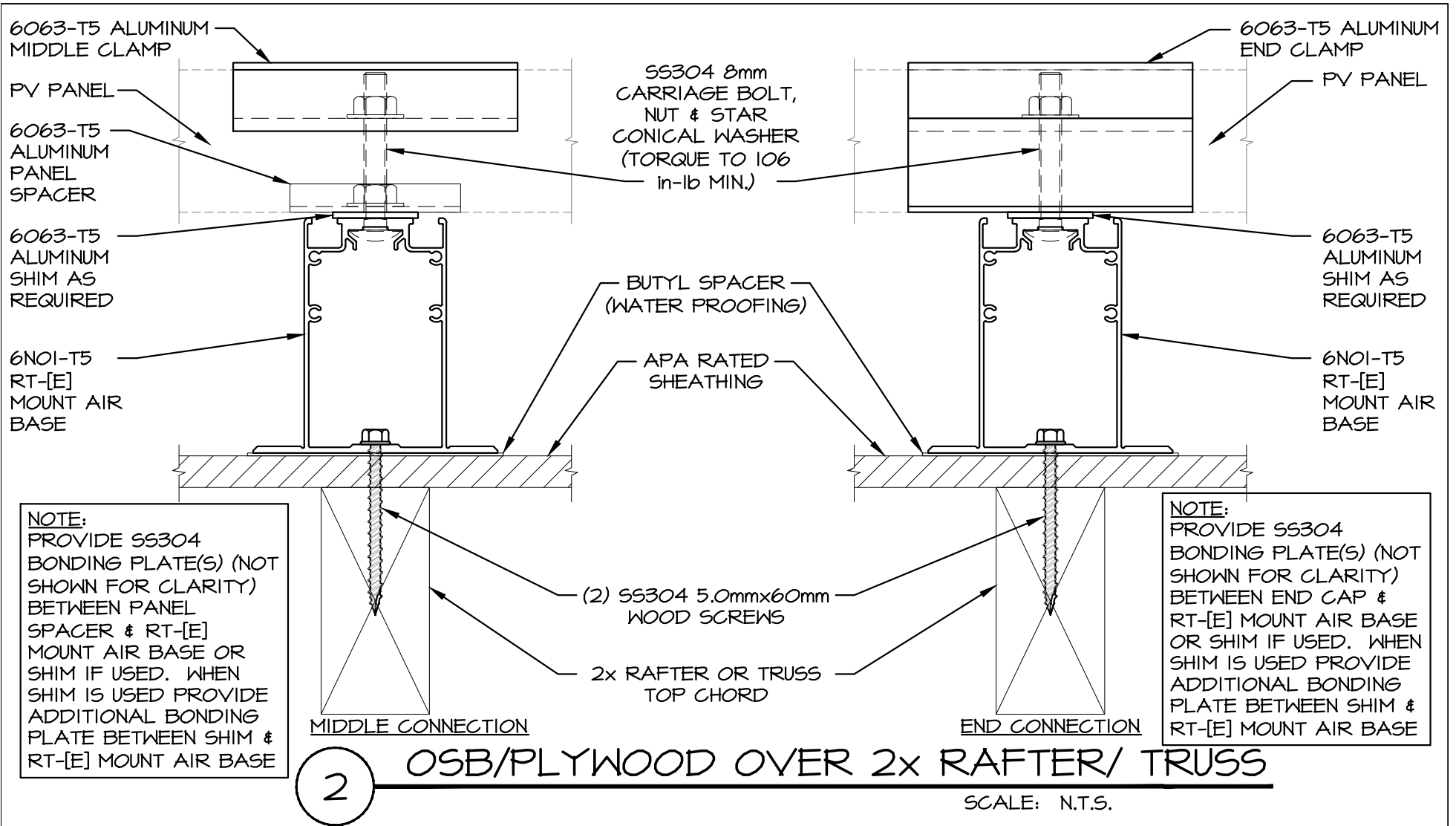

Starling Madison Lofquist, Inc.

5224 S. 39th Street  
 Phoenix, Arizona 85040  
 (602) 438-2500  
 fax. (602) 438-2505

DRAWN BY: T.M.  
 DESIGNED BY: J.L.

DATE: 7-21-15  
 JOB NO: 471-13

ROOF TECH  
 RT-[E] MOUNT AIR  
 STRUCTURAL ANALYSIS

ROOF TECH, INC.  
 333 H STREET, SUITE 5000  
 CHULA VISTA, CA 91910

EXHIBIT A  
 2 OF 4

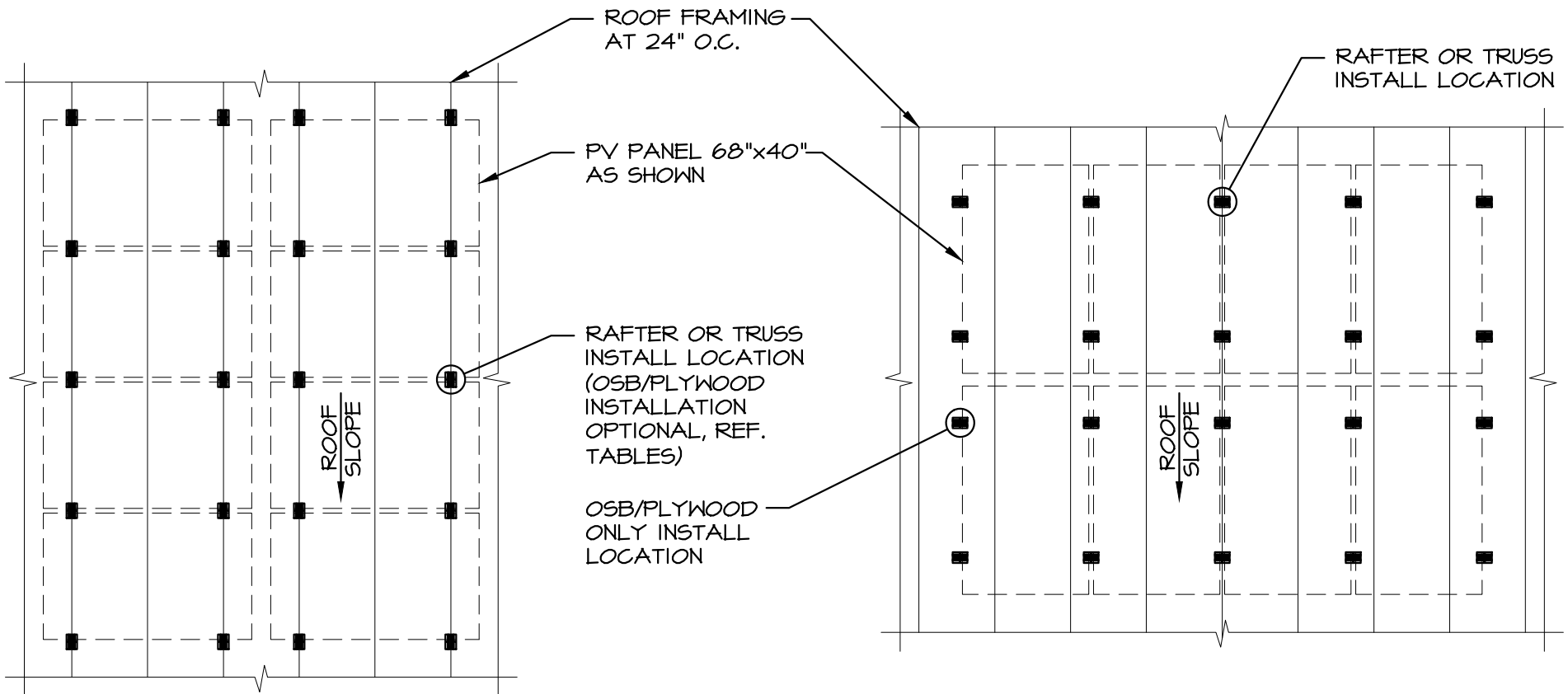

PV PANEL IN LANDSCAPE ORIENTATION

PV PANEL IN PORTRAIT ORIENTATION

3 PARTIAL FRAMING PLAN (4 MOUNTS PER PANEL)

SCALE: N.T.S.



Starling Madison Lofquist, Inc.  
 5224 S. 39th Street  
 Phoenix, Arizona 85040  
 (602) 438-2500  
 fax. (602) 438-2505

DRAWN BY: T.M.  
 DESIGNED BY: J.L.

DATE: 7-21-15  
 JOB NO: 471-13

ROOF TECH  
 RT-[E] MOUNT AIR  
 STRUCTURAL ANALYSIS

ROOF TECH, INC.  
 333 H STREET, SUITE 5000  
 CHULA VISTA, CA 91910

EXHIBIT A  
 3 OF 4



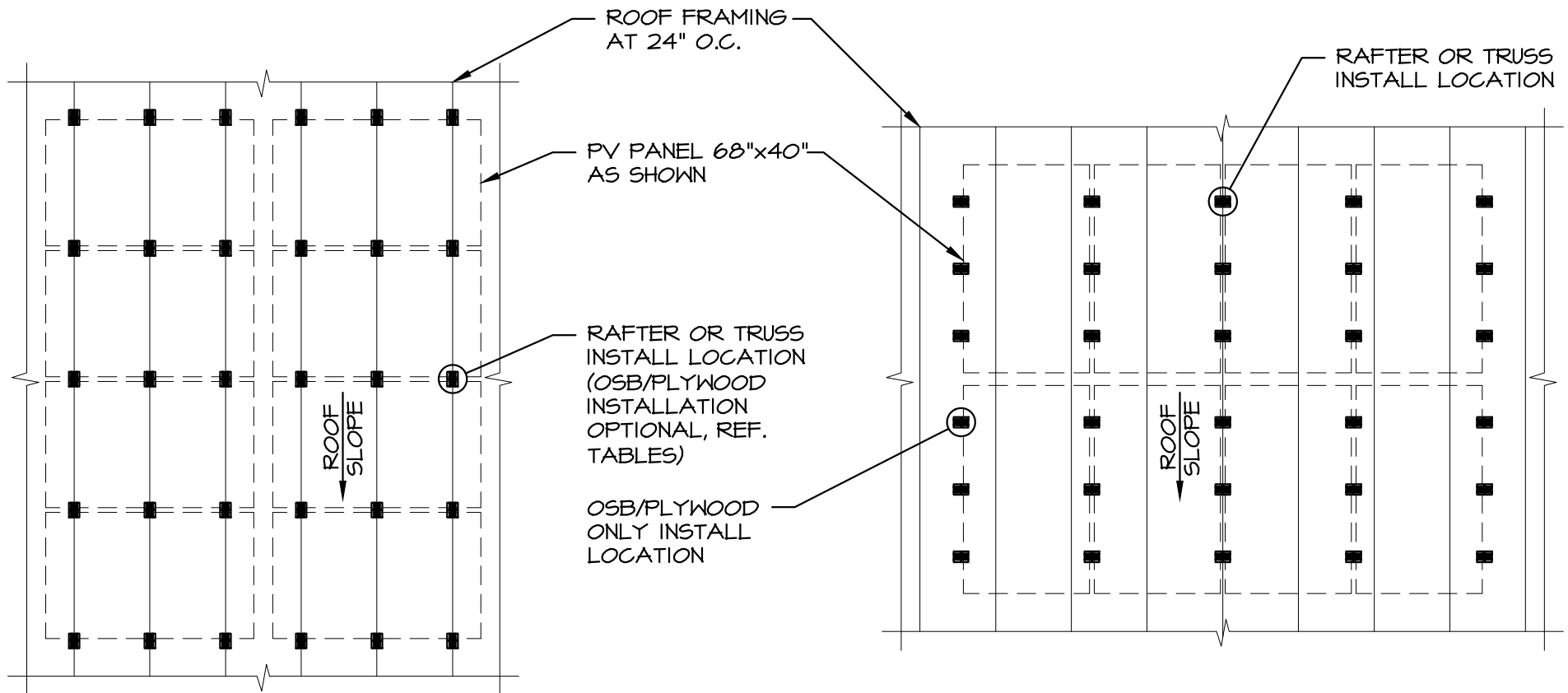

PV PANEL IN LANDSCAPE ORIENTATION

PV PANEL IN PORTRAIT ORIENTATION

**PARTIAL FRAMING PLAN (6 MOUNTS PER PANEL)**

4

SCALE: N.T.S.



Consulting Structural and Forensic Engineers

Starling Madison Lofquist, Inc.

5224 S. 39th Street  
 Phoenix, Arizona 85040  
 (602) 438-2500  
 fax. (602) 438-2505

DRAWN BY: T.M.  
 DESIGNED BY: J.L.

DATE: 7-21-15  
 JOB NO: 471-13

ROOF TECH  
 RT-[E] MOUNT AIR  
 STRUCTURAL ANALYSIS

ROOF TECH, INC.  
 333 H STREET, SUITE 5000  
 CHULA VISTA, CA 91910

EXHIBIT A  
 4 OF 4

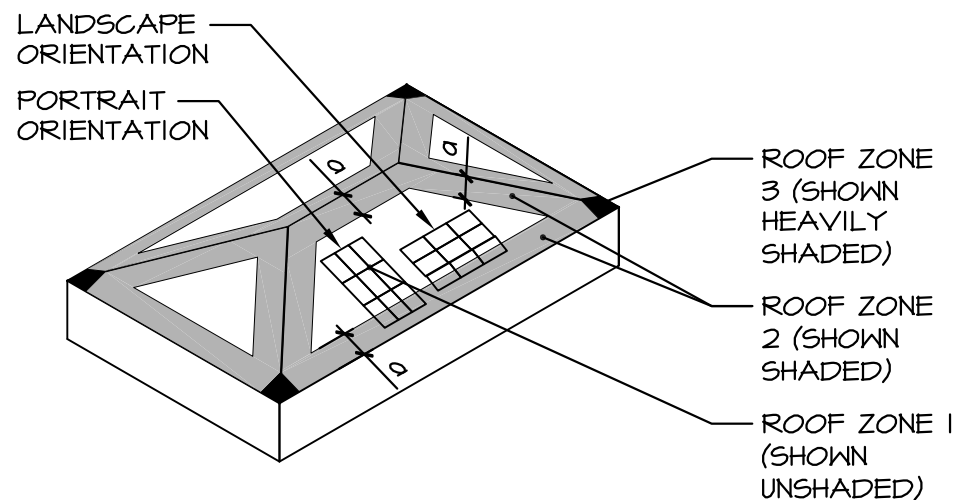
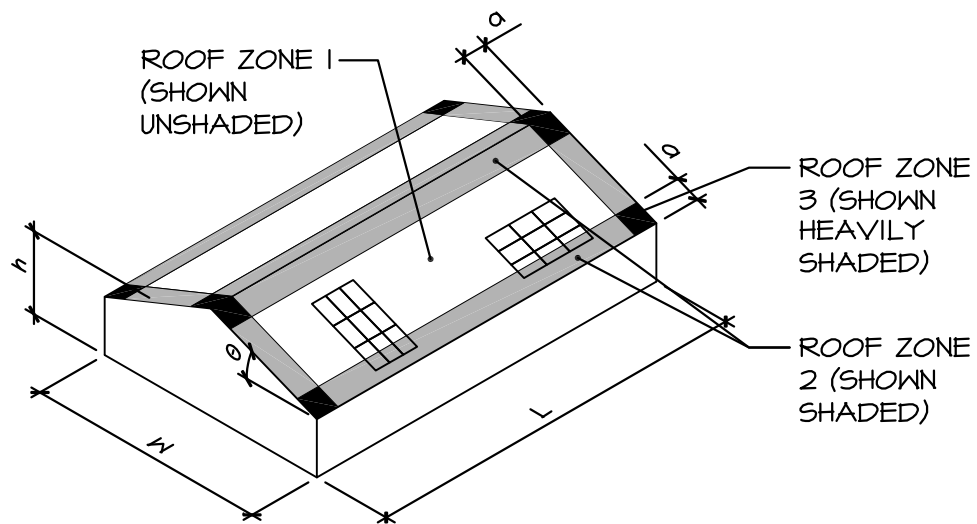

**DEFINITIONS:**

(REF. ASCE 7-10, FIGURES 30.4-1, 30.4-2A, 30.4-2B, 30.4-2C)

$a$  = 10% OF LEAST HORIZONTAL DIMENSION ( $0.1W$ ) OR  $0.4h$ , WHICHEVER IS SMALLER, BUT NOT LESS THAN 3 FT OR 4% OF LEAST HORIZONTAL DIMENSION ( $0.04W$ ).

$W$  = HORIZONTAL WIDTH OF BUILDING.

$L$  = HORIZONTAL LENGTH OF BUILDING.

$h$  = MEAN ROOF HEIGHT, MEASURED VERTICALLY FROM ADJACENT GRADE, EXCEPT THAT EAVE HEIGHT SHALL BE USED FOR  $\theta \leq 10^\circ$ .

$\theta$  = ANGLE OF PLANE OF ROOF FROM HORIZONTAL IN DEGREES.

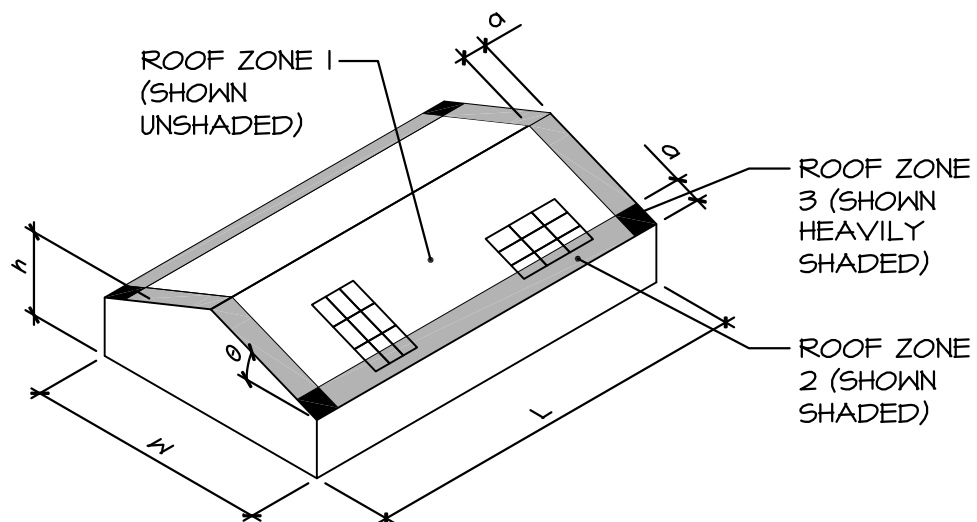

**FIGURE 1**

WIND ZONE DIAGRAM

SCALE: \_\_\_\_\_ NTS



Starling Madison Lofquist, Inc.

5224 S. 39th Street  
 Phoenix, Arizona 85040  
 (602) 438-2500  
 fax. (602) 438-2505

Consulting Structural and  
 Forensic Engineers